

# AEG

## POWERTOOLS

**ACS18B30**

**ACS183060**

Original instructions

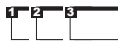



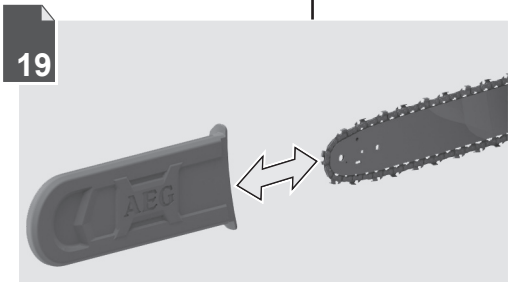
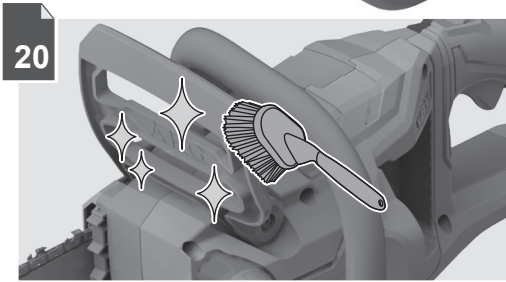
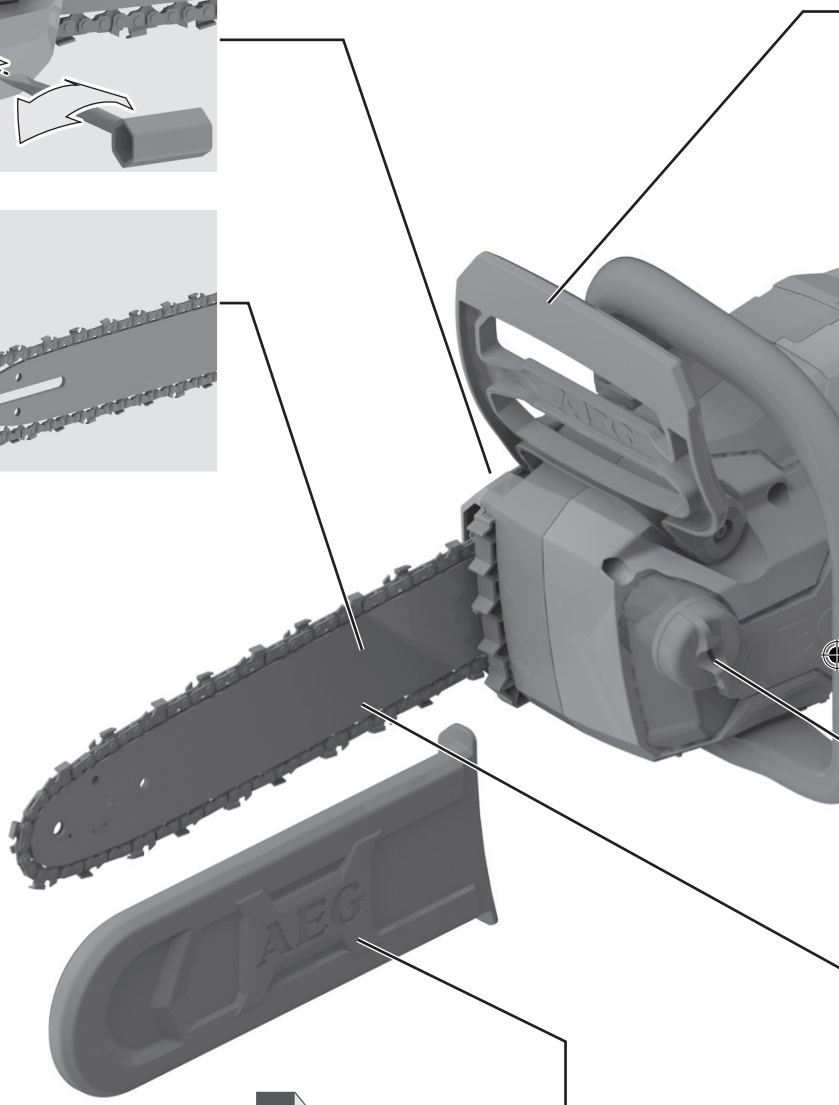
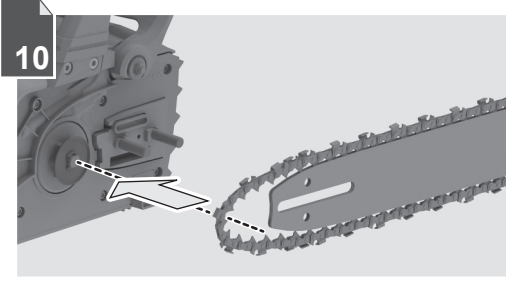
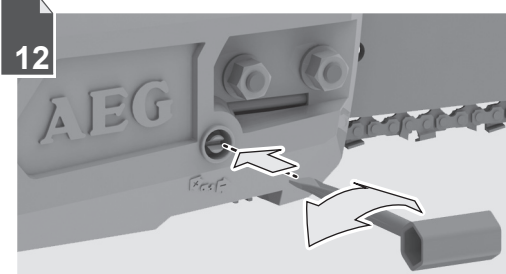

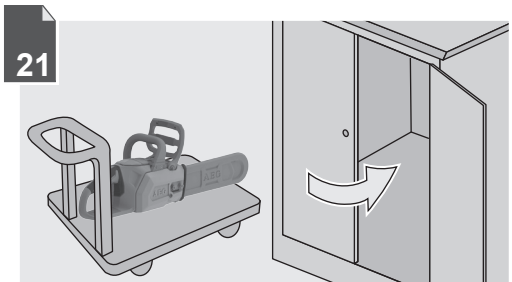
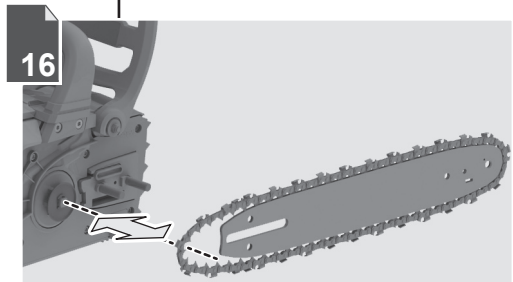
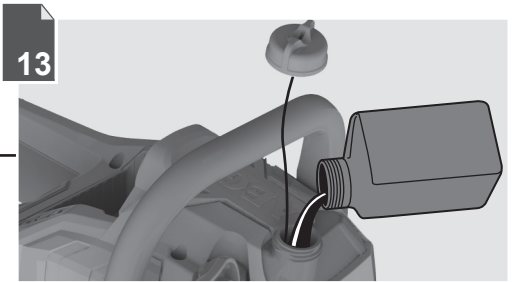
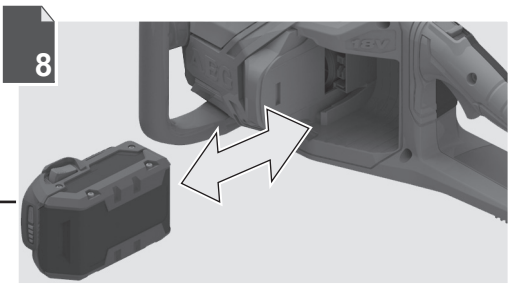
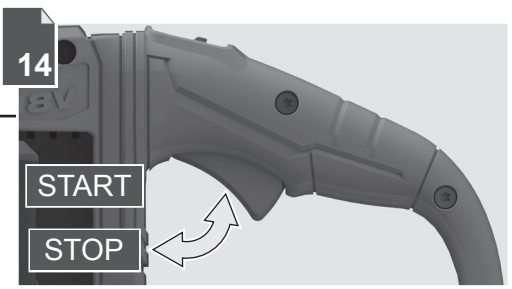
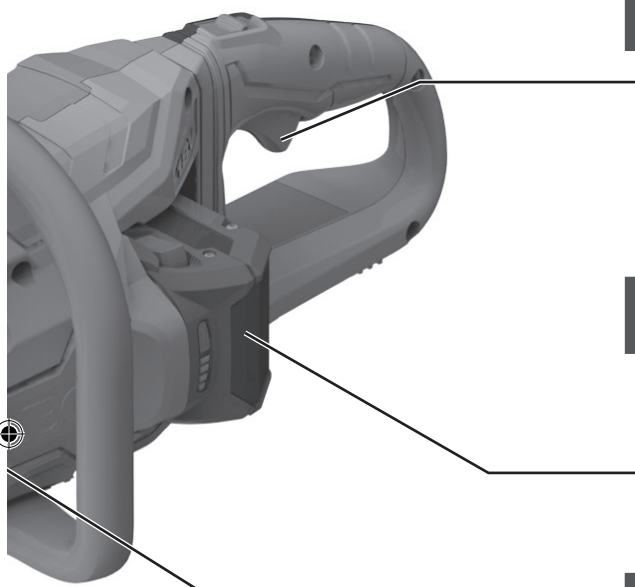
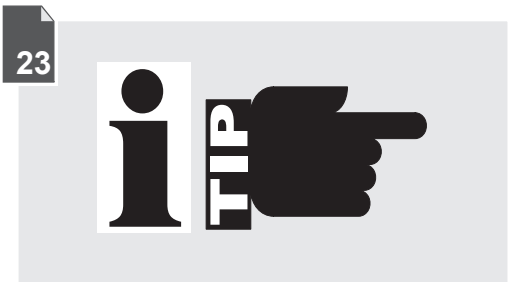
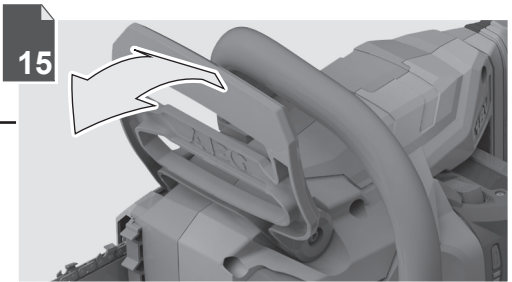

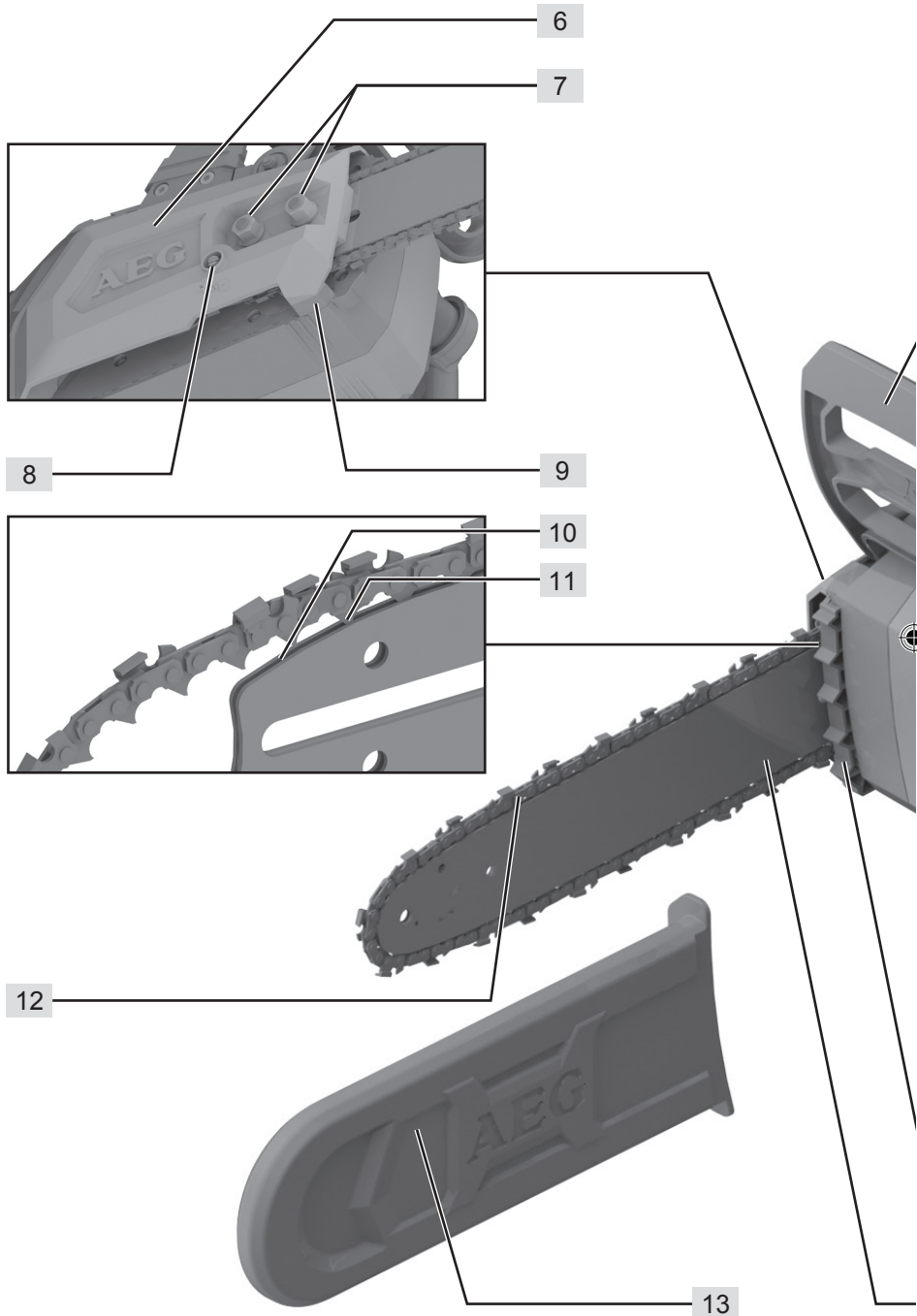

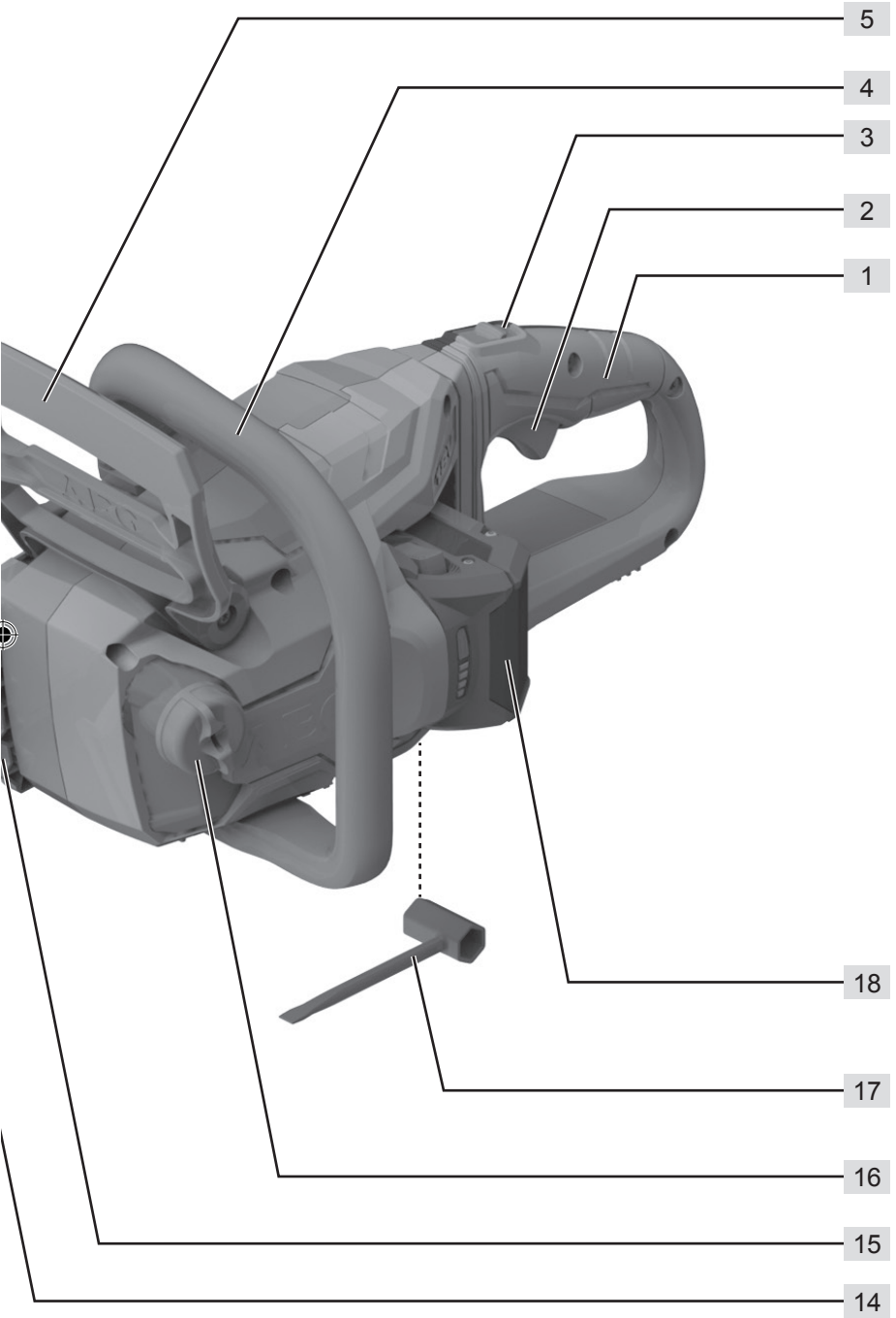

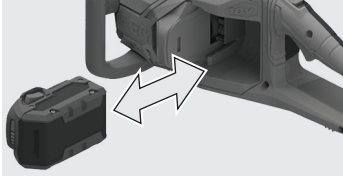

Remove the battery pack before starting any work on the machine.

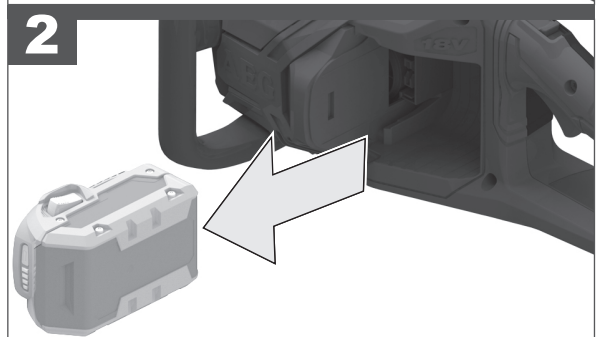
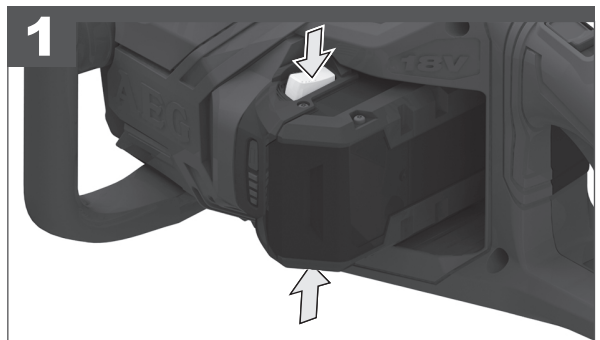
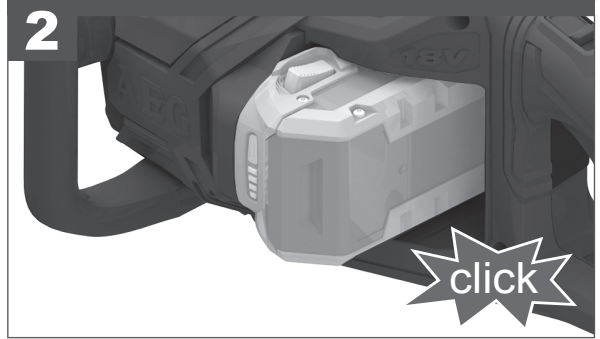
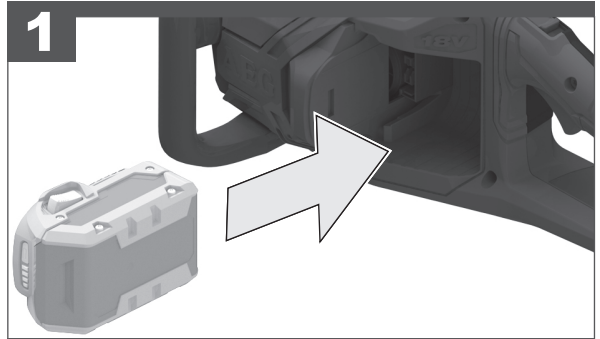



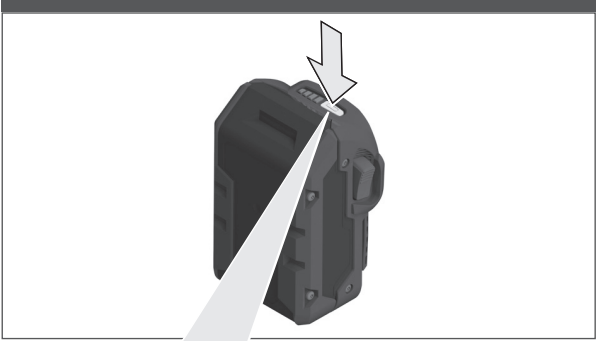

		75-100 %
		50-75 %
		25-50 %
		0-25 %



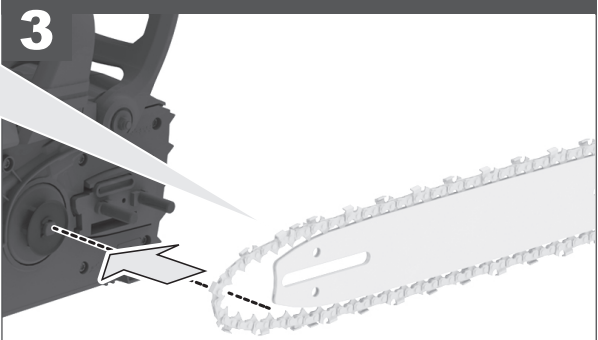
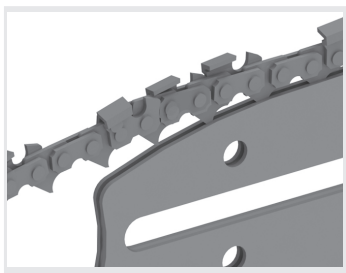
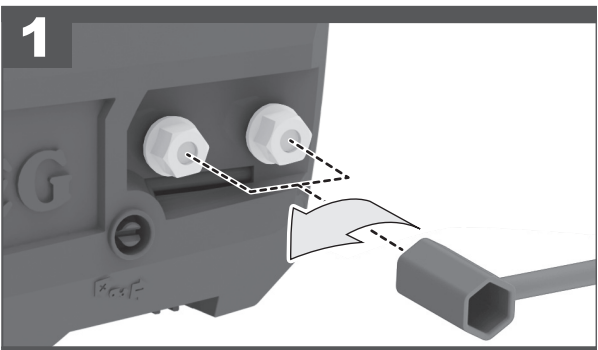
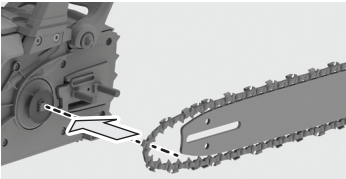



Only finger-tighten!

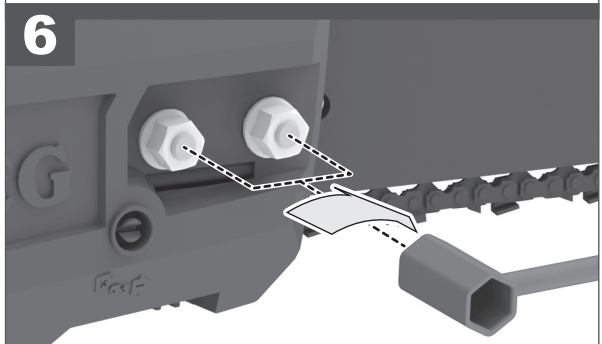
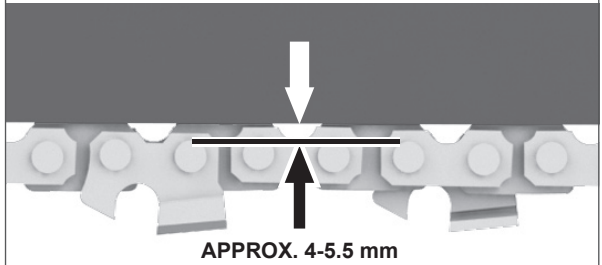
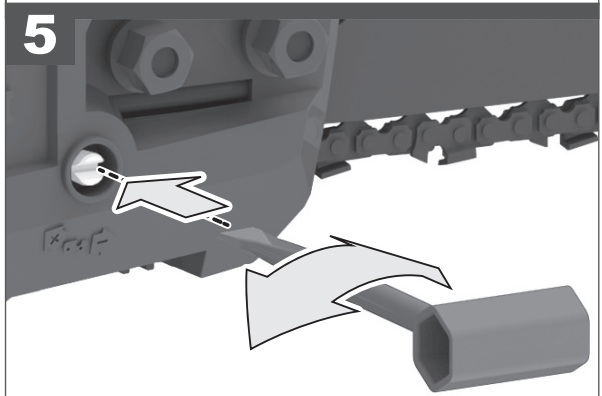

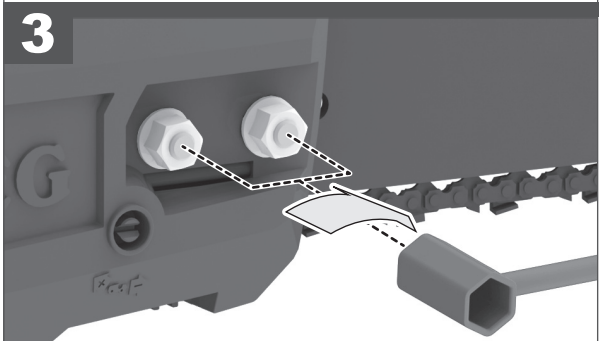
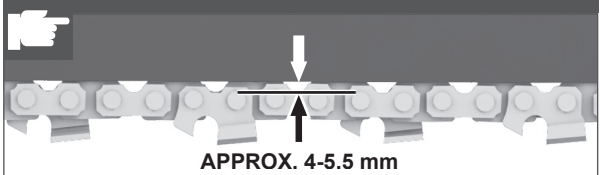
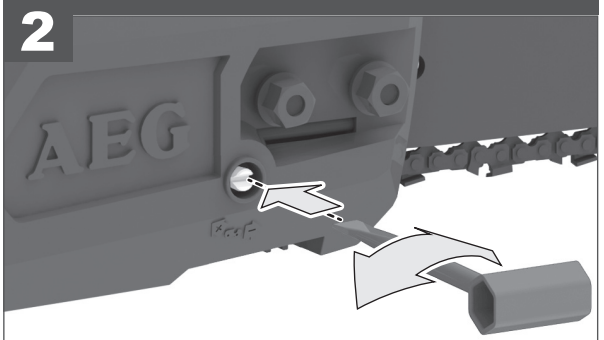
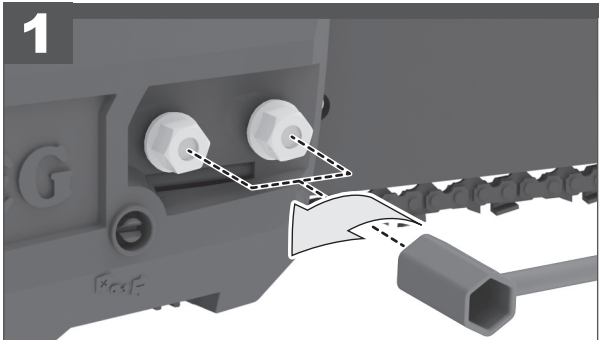
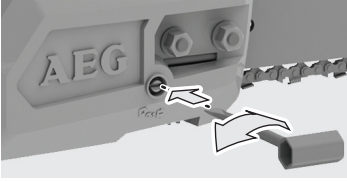

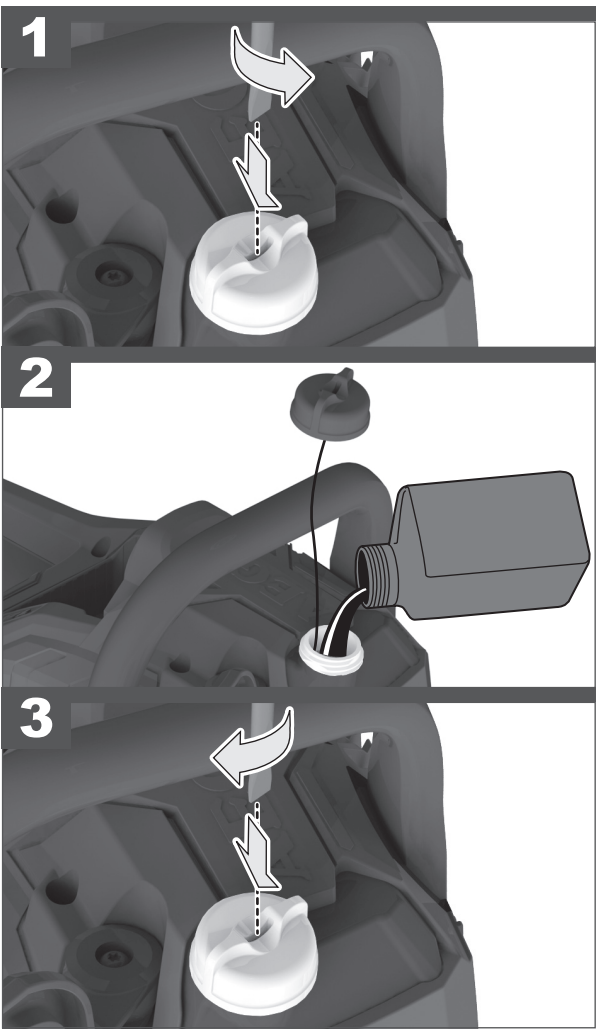
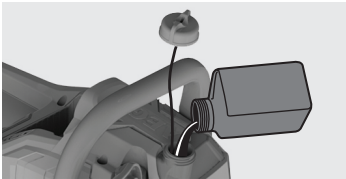

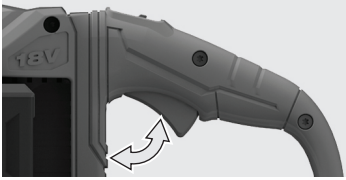

# START

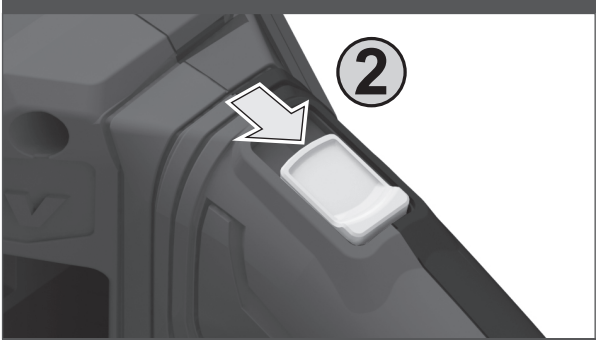
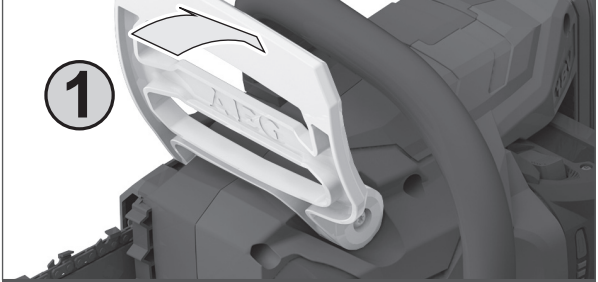

# STOP

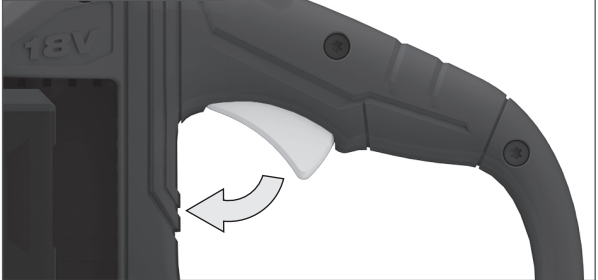

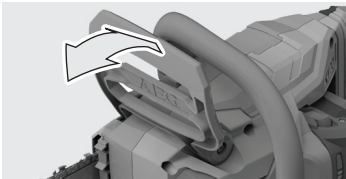

**BRAKE ON**

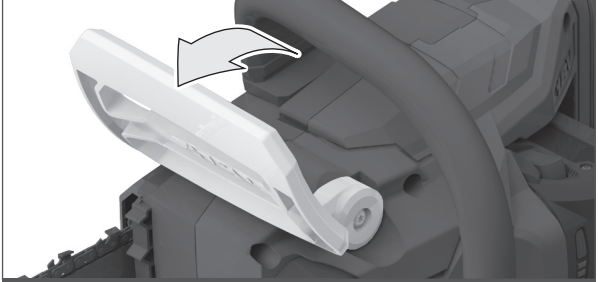

**BRAKE OFF**

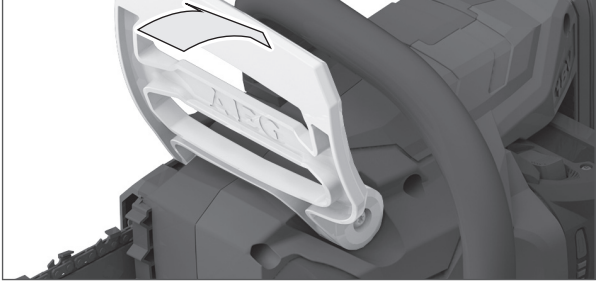

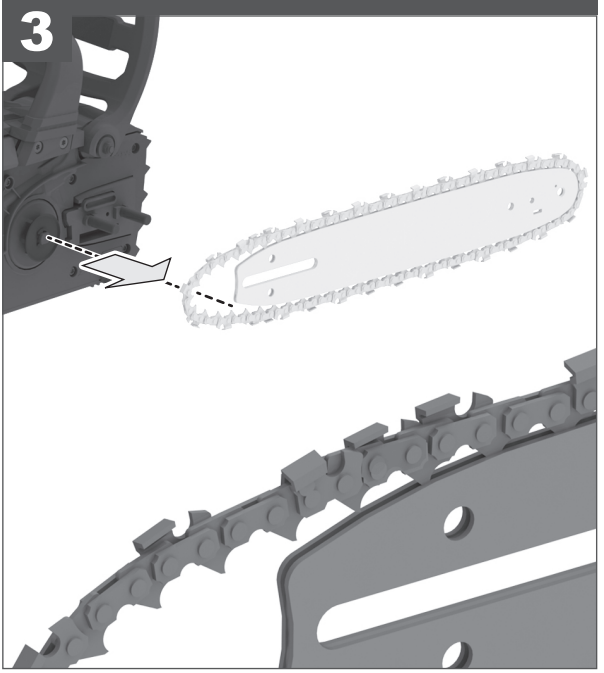
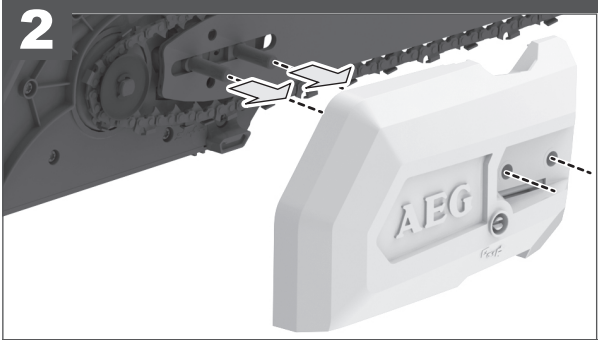
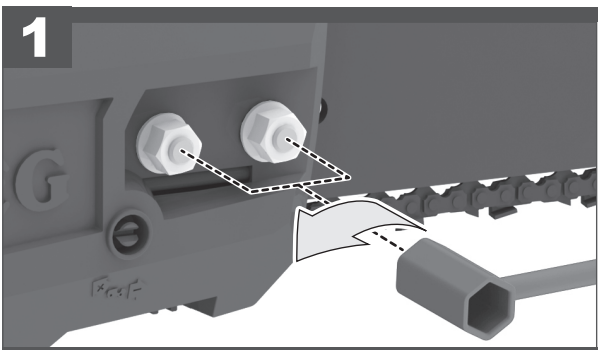
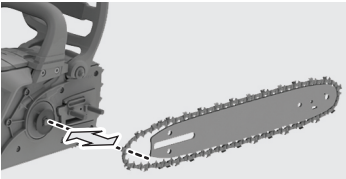



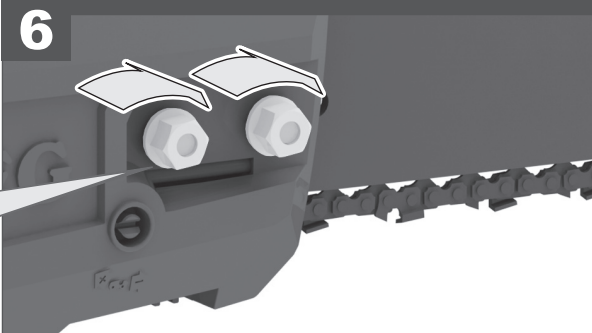
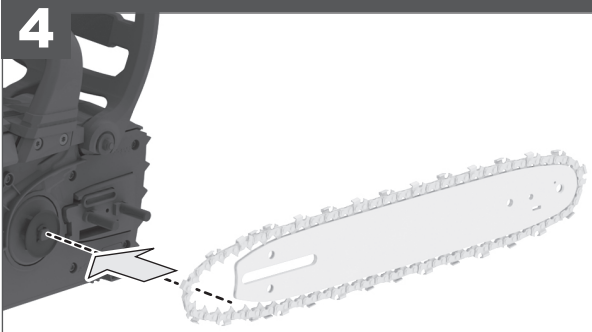

Only finger-tighten!

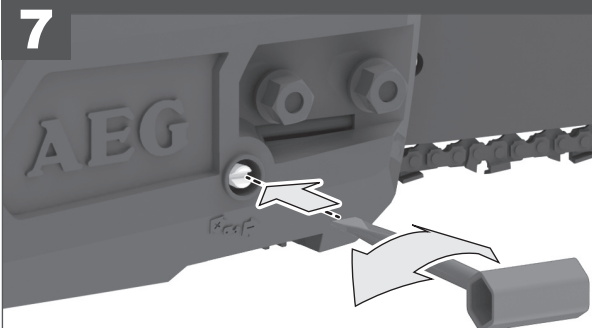

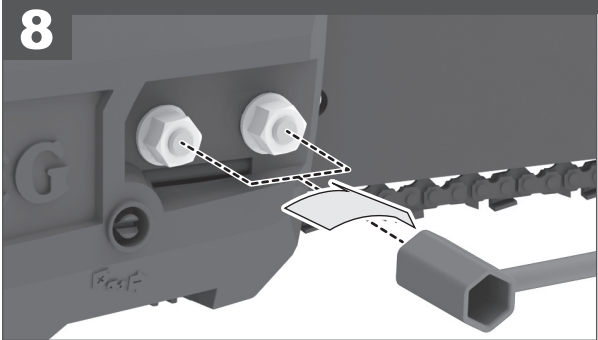
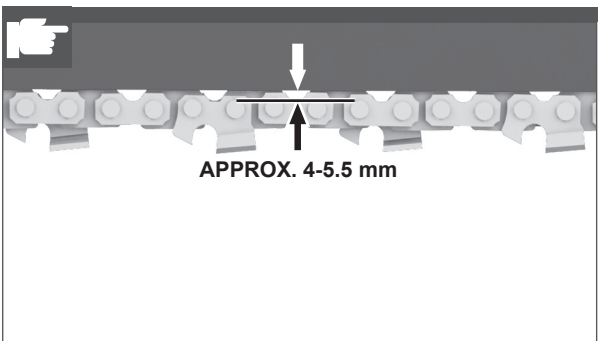

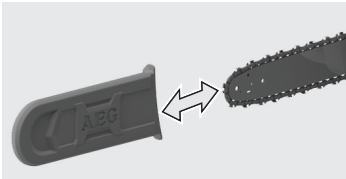

**1**

**2**



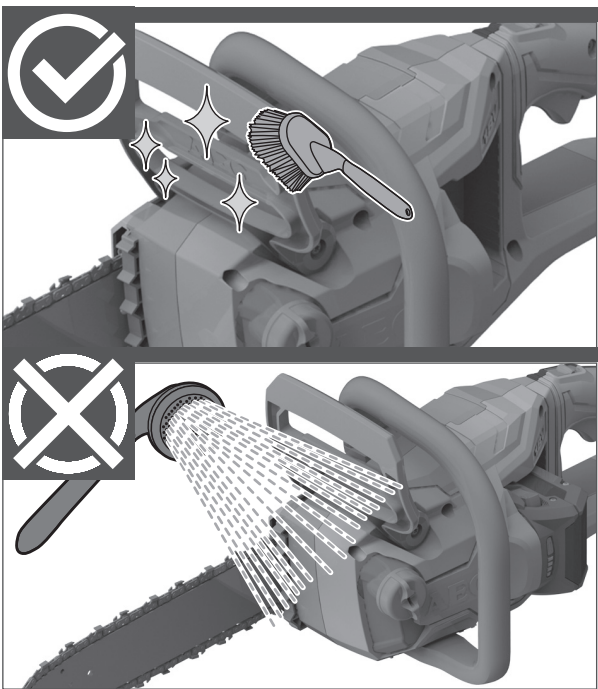
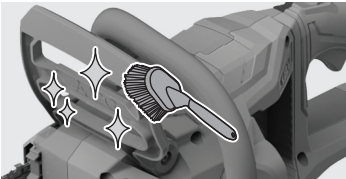

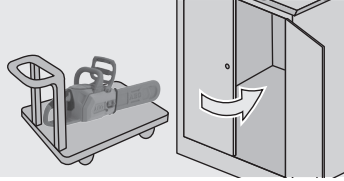

1

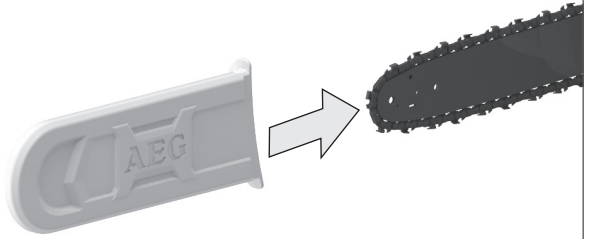

2

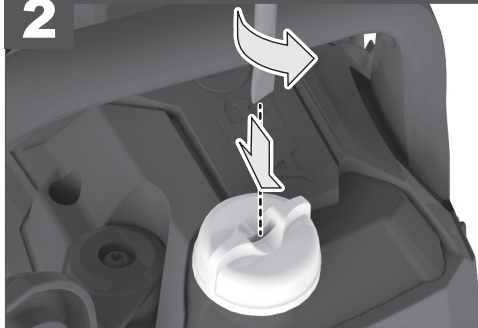

3

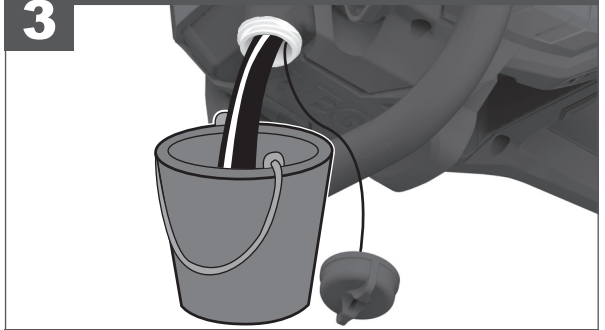

4

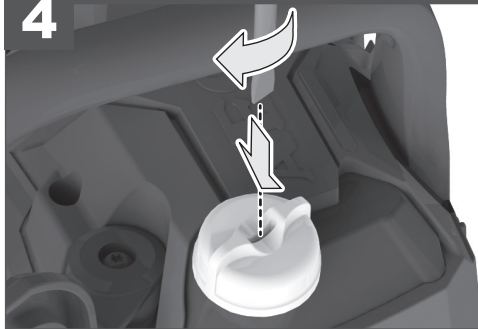

5

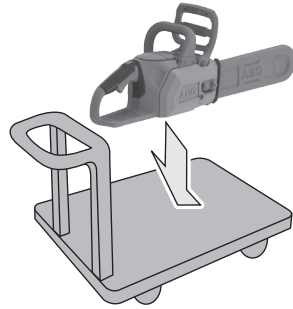

6

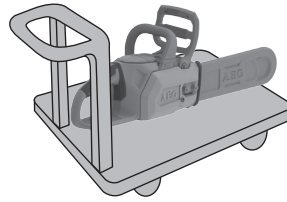

# i TIP

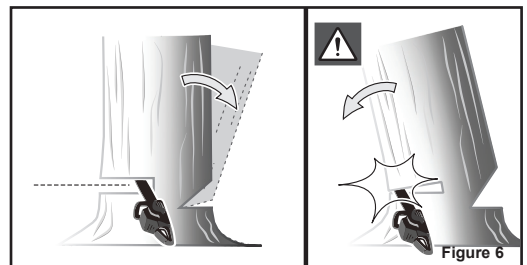
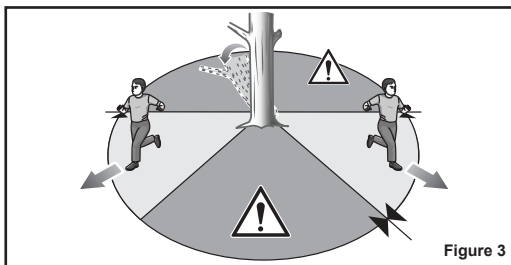
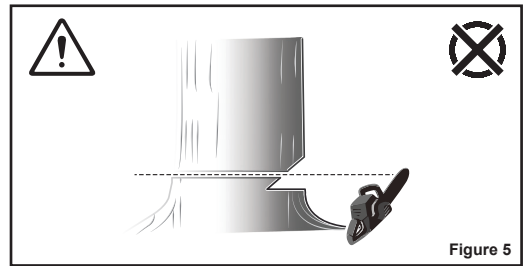
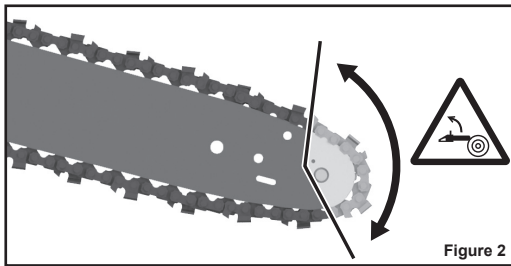
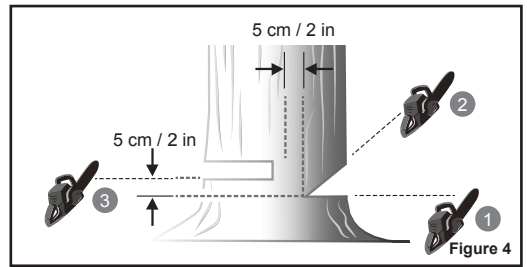
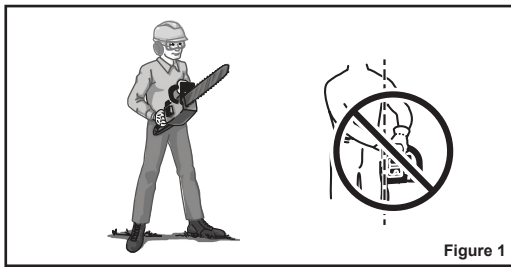
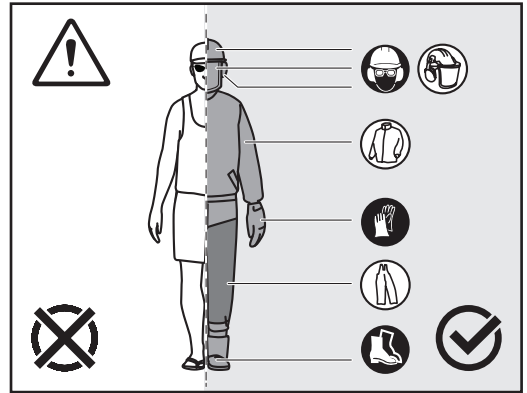
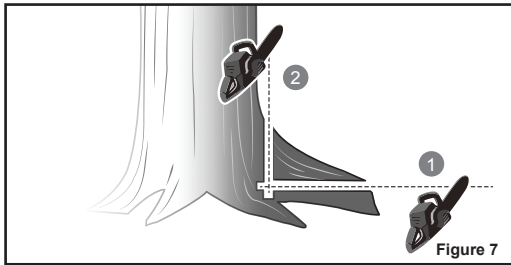

Figure 7

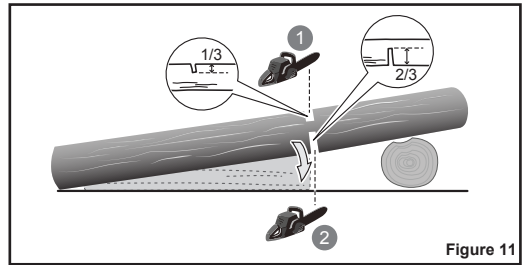

Figure 11

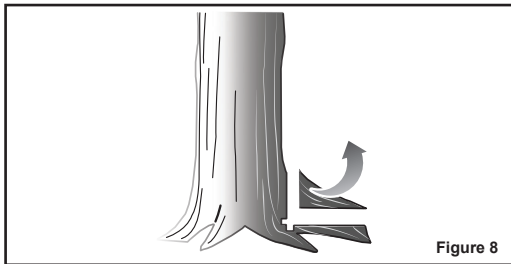

Figure 8

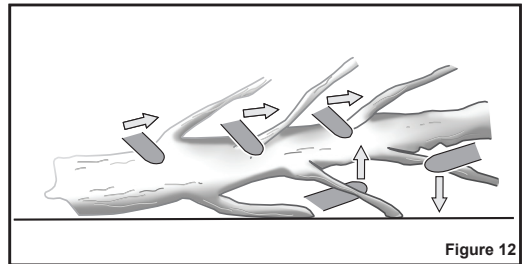

Figure 12

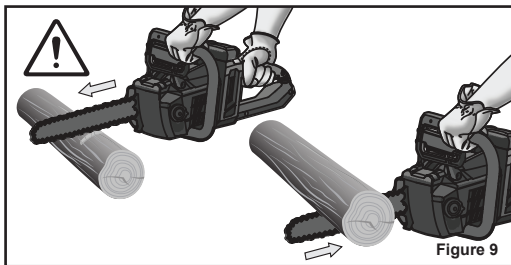

Figure 9

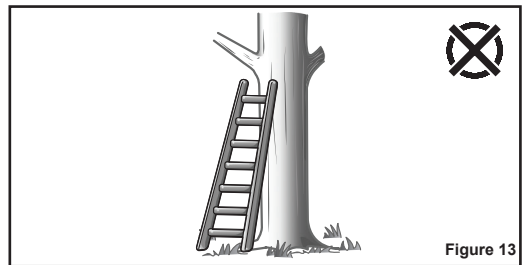

Figure 13

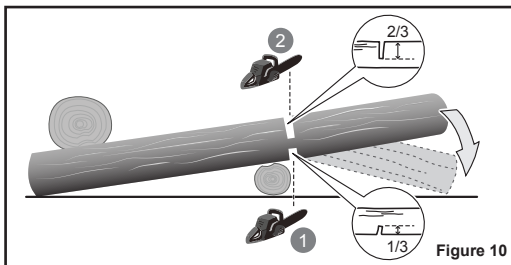

Figure 10

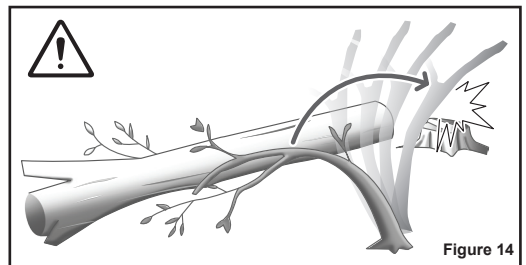

Figure 14

V  
T  
A  
T  
d  
b  
k  
t  
L  
F  
S  
S  
K  
c  
s  
i  
r  
y  
A  
h  
c  
p  
F  
b  
c  
t  
V  
e  
A  
d



**TECHNICAL DATA****CORDLESS CHAINSAW****ACS18B30****ACS183060**

Production code.....	4000 4604 70 01.....	4000 4604 70 01
	000001-999999.....	000001-999999
No-load speed.....	10 m/s.....	10 m/s
Max bar length.....	300 mm (12").....	300 mm (12")
Usable cutting length.....	250 mm.....	250 mm
Battery voltage.....	18 V.....	18 V
Weight according EPTA-Procedure 01/2003 (with 6.0 Ah battery pack).....	4.05 kg.....	4.05 kg
Weight (without battery pack).....	3.3 kg.....	3.3 kg
Noise/vibration information		
Measured values determined according to EN 60745-2-13.		
Typically, the A-weighted noise levels of the tool are:		
Sound pressure level (Uncertainty K= 2.5 dB).....	85.3 dB(A).....	85.3 dB(A)
Sound power level (Uncertainty K= 2.5 dB).....	96.3 dB(A).....	96.3 dB(A)
Always wear ear protectors!		
Total vibration values (vector sum in the three axes) determined according to EN 60745-2-13.		
Vibration emission value a <sub>h</sub>		
Rear handle.....	9.5 m/s <sup>2</sup> .....	9.5 m/s <sup>2</sup>
Front handle.....	6.1 m/s <sup>2</sup> .....	6.1 m/s <sup>2</sup>
Uncertainty K.....	1.5 m/s <sup>2</sup> .....	1.5 m/s <sup>2</sup>

**WARNING!**

The vibration emission level given in this information sheet has been measured in accordance with a standardised test given in EN 60745 and may be used to compare one tool with another. It may be used for a preliminary assessment of exposure.

The declared vibration emission level represents the main applications of the tool. However if the tool is used for different applications, with different accessories or poorly maintained, the vibration emission may differ. This may significantly increase the exposure level over the total working period.

An estimation of the level of exposure to vibration should also take into account the times when the tool is switched off or when it is running but not actually doing the job. This may significantly reduce the exposure level over the total working period.

Identify additional safety measures to protect the operator from the effects of vibration such as: maintain the tool and the accessories, keep the hands warm, organisation of work patterns.

**⚠ WARNING! Read all safety warnings and all instructions.** Failure to follow the warnings and instructions may result in electric shock, fire and/or serious injury.

**Save all warnings and instructions for future reference.**

**CHAINSAW SAFETY WARNINGS**

**Keep all parts of the body away from the saw chain when operating the product. Before you start the chainsaw, make sure the saw chain is not contacting anything.** A moment of inattention while operating chainsaws may cause entanglement of your clothing or body with the saw chain.

**Always hold the chainsaw with your right hand on the rear handle and your left hand on the front handle.** Holding the chainsaw with a reversed hand configuration increases the risk of personal injury and should never be done.

**Hold the product by the insulated gripping surface only, because the saw chain may contact hidden wiring.** Saw chains contacting a "live" wire may make exposed metal parts of the power tool "live" and could give the operator an electric shock.

**Wear safety glasses and hearing protection. Further protective equipment for head, hands, legs and feet is recommended.** Adequate protective clothing will reduce personal injury by flying debris or accidental contact with the saw chain.

**Do not operate a chainsaw in a tree.** Operation of a chainsaw while up in a tree may result in personal injury.

**Always keep proper footing and operate the chainsaw only when standing on fixed, secure and level surface.** Slippery or unstable surfaces such as ladders may cause a loss of balance or control of the chainsaw.

**When cutting a limb that is under tension be alert for spring back.** When the tension in the wood fibres is released the spring loaded limb may strike the operator and/or throw the chainsaw out of control.

**Use extreme caution when cutting brush and saplings.** The slender material may catch the saw chain and be whipped toward you or pull you off balance.

**Carry the chainsaw by the front handle with the chainsaw switched off and away from your body. When transporting or storing the chainsaw always fit the guide bar cover.** Proper handling of the chainsaw will reduce the likelihood of accidental contact with the moving saw chain.

**Follow instructions for lubricating, chain tensioning and changing accessories.** Improperly tensioned or lubricated chain may either break or increase the chance for kickback.

**Keep handles dry, clean, and free from oil and grease.** Greasy, oily handles are slippery causing loss of control.





**Cut wood only. Do not use chainsaw for purposes not intended. For example: do not use chainsaw for cutting plastic, masonry or non-wood building materials.** Use of the chainsaw for operations different than intended could result in a hazardous situation.

**Causes and operator prevention of kickback:**

Kickback may occur when the nose or tip of the guide bar touches an object, or when the wood closes in and pinches the saw chain in the cut.

Tip contact in some cases may cause a sudden reverse reaction, kicking the guide bar up and back towards the operator.

Pinching the saw chain along the top of the guide bar may push the guide bar rapidly back towards the operator.

Either of these reactions may cause you to lose control of the saw which could result in serious personal injury. Do not rely exclusively upon the safety devices built into your saw. As a chainsaw user, you should take several steps to keep your cutting jobs free from accident or injury.

Kickback is the result of tool misuse and/or incorrect operating procedures or conditions and can be avoided by taking proper precautions as given below:

**Maintain a firm grip, with thumbs and fingers encircling the chainsaw handles, with both hands on the saw and position your body and arm to allow you to resist kickback forces.** Kickback forces can be controlled by the operator, if proper precautions are taken. Do not let go of the chainsaw.

**Do not overreach and do not cut above shoulder height.** This helps prevent unintended tip contact and enables better control of the chainsaw in unexpected situations.

**Only use replacement bars and chains specified by the manufacturer.** Incorrect replacement bars and chains may cause chain breakage and/or kickback.

**Follow the manufacturer's sharpening and maintenance instructions for the saw chain.** Decreasing the depth gauge height can lead to increased kickback.

**ADDITIONAL CHAINSAW SAFETY WARNINGS**

It is recommended to cut logs on a saw-horse or cradle when operating the product for the first time.

Ensure all guards, handles, and spiked bumper are properly fitted and are in good condition.

Persons using the product should be in good health. The product is heavy, so the operator must be physically fit. The operator should be alert, have a good vision, mobility, balance, and manual dexterity. If there is any doubt, do not operate the product.

Do not start using the product until you have a clear work area, secure footing, and a planned retreat path away from a falling tree.

Beware of the emission of lubricant mist and saw dust. Wear a mask or respirator, if required.

Do not cut vines and/or small undergrowth (less than 75 mm in diameter).

Always hold the chainsaw with both hands during operation. Use a firm grip with thumbs and fingers encircling the chainsaw handles. Right hand must be on the rear handle and left hand on the front handle.

Before starting the product, make sure the saw chain is not contacting any object.

Do not modify the product in any way or use it to power any attachments or devices not recommended by the manufacturer for your saw.

There should be a first-aid kit containing large wound dressings and a means to summon attention (e.g., whistle) close to the operator. A larger more comprehensive kit should be reasonably nearby.

Wear a helmet at all times when operating the product. A helmet, equipped with mesh visor, can help reduce the risk of injury to the face and the head if kickback occurs.

An incorrectly tensioned chain can jump off the guide bar and could result in serious injury or fatality. The length of the chain depends on the temperature. Check the tension frequently.

You should get used to your new chainsaw by making simple cuts on securely supported wood. Do this whenever you have not operated the saw for some time.

To reduce the risk of injury associated with contacting moving parts, always stop the motor, apply the chain brake, remove the battery pack and make sure all moving parts have come to a stop before:

- cleaning or clearing a blockage
- leaving the product unattended
- installing or removing attachments
- checking, conducting maintenance or working on the product

The size of the work area depends on the job being performed as well as the size of the tree or work piece involved. For example, felling a tree requires a larger work area than making other cuts, i.e., bucking cuts, etc. The operator needs to be aware and in control of everything happening in the work area.

Do not cut with your body in line with the guide bar and chain. If you experience kickback, this will help prevent the chain coming into contact with your head or body.

Do not use a back-and-forward sawing motion, let the chain do the work. Keep the chain sharp and do not try to push the chain through the cut.

Do not put pressure on the saw at the end of the cut. Be ready to take on the weight of the saw as it cuts free from the wood. Failure to do so could result in possible serious personal injury.

Do not stop the saw in the middle of a cutting operation. Keep the saw running until it is already removed from the cut.

**Push and pull**

See figure 9.

The reaction force is always opposite to the direction the chain is moving. Thus, the operator must be ready to control the tendency for the product to pull away (forward motion) when cutting on the bottom edge of the bar and the push backwards (towards the operator) when cutting along the top edge.

**Saw jammed in the cut**

Stop the chainsaw and make it safe. Do not try to force the chain and bar out of the cut as this is likely to break the chain, which may swing back and strike the operator. This situation normally occurs because the wood is incorrectly supported which forces the cut to close under compression, thereby pinching the blade. If adjusting the support does not release the bar and chain, use wooden wedges or a lever to open the cut and release the saw. Never try to start the chainsaw when the guide bar is already in a cut or kerf.

**Personal protective equipment**

See page 23.

Good quality, personal protective equipment as used by professionals will help to reduce the risk of injury to the operator. The following items should be used when operating your chainsaw:

**Safety helmet**

- should comply with EN 397 and be CE marked

**Hearing protection**

- should comply with EN 352-1 and be CE marked

**Eye and face protection**

- should be CE marked and comply with EN 166 (for safety glasses) or EN 1731 (for mesh visors)



## Gloves

- should comply with EN381-7 and be CE marked

## Leg protection (chaps)

- should comply with EN381-5, be CE marked and provide all-round protection.

## Chainsaw safety boots

- should comply with EN ISO 20345:2004 and be marked with a shield depicting a chainsaw to show compliance with EN 381-3. (Occasional users may use steel toe-cap safety boots with protective gaiters which conform to EN 381-9 if the ground is even and there is little risk of tripping or catching on undergrowth)

## Chainsaw jackets for upper body protection

- should comply with EN 381-11 and be CE marked

## INSTRUCTIONS CONCERNING THE PROPER TECHNIQUES FOR BASIC FELLING, LIMBING, AND CROSS-CUTTING

### Understanding the forces within the wood

When you understand the directional pressures and stresses inside the wood you can reduce the “pinches” or at least expect them during your cutting. Tension in the wood means the fibers are being pulled apart and if you cut in this area, the “kerf” or cut will tend to open as the saw goes through. If a log is being supported on a saw horse and the end is hanging unsupported over the end, tension is created on the upper surface due to the weight of the overhanging log stretching the fibers. Likewise, the underside of the log will be in compression and the fibers are being pushed together. If a cut is made in this area, the kerf will have the tendency to close up during the cut. This would pinch the blade.

### Felling a tree

See figures 1 - 8.

When bucking and felling operations are being performed by two or more persons at the same time, the felling operations should be separated from the bucking operation by a distance of at least twice the height of the tree being felled. Trees should not be felled in a manner that would endanger any person, strike any utility line, or cause any property damage. If the tree does make contact with any utility line, the company should be notified immediately.

The chainsaw operator should keep on the uphill side of the terrain as the tree is likely to roll or slide downhill after it is felled.

An escape path should be planned and cleared as necessary before cuts are started. The escape path should extend back and diagonally to the rear of the expected line of fall.

Before felling starts, consider the natural lean of the tree, the location of larger branches, and the wind direction to judge which way the tree will fall.

Remove dirt, stones, loose bark, nails, staples, and wire from the tree.

Do not attempt to fell trees which are rotten or have been damaged by wind, fire, lightning, etc. This is extremely dangerous and should only be completed by professional tree surgeons.

#### 1. Notching undercut

See figures 1 - 6.

Make the notch 1/3 the diameter of the tree, perpendicular to the direction of the fall. Make the lower horizontal notching cut first. This will help to avoid pinching either the saw chain or the guide bar when the second notch is being made.

#### 2. Felling-back cut

See figures 1 - 6.

Make the felling-back cut at least 50 mm/2 in. higher than the horizontal notching cut. Keep the felling-back cut parallel to the horizontal notching cut. Make the felling back cut so enough

wood is left to act as a hinge. The hinge wood keeps the tree from twisting and falling in the wrong direction. Do not cut through the hinge.

As the felling gets close to the hinge, the tree should begin to fall. If there is any chance that the tree may not fall in the desired direction or it may rock back and bind the saw chain, stop cutting before the felling-back cut is complete and use wedges of wood, plastic or aluminium to open the cut and drop the tree along the desired line of fall.

When the tree begins to fall remove the chainsaw from the cut, stop the motor, put the chainsaw down, and use the retreat path planned. Be alert for falling overhead limbs and watch your footing.

### Removing buttress roots

See figures 7 - 8.

A buttress root is a large root extending from the trunk of the tree above the ground. Remove large buttress roots prior to felling. Make the horizontal cut into the buttress first, followed by the vertical cut. Remove the resulting loose section from the work area. Follow the correct tree felling procedure after you have removed the large buttress roots.

### Bucking a log

See figures 9 - 11.

Bucking is cutting a log into lengths. It is important to make sure your footing is firm and your weight is evenly distributed on both feet. When possible, the log should be raised and supported by the use of limbs, logs or chocks. Follow the simple directions for easy cutting. When the log is supported along its entire length, it is cut from the top (overbuck).

When the log is supported on one end, cut 1/3 the diameter from the underside (underbuck). Then make the finished cut by overbucking to meet the first cut.

When the log is supported on both ends, cut 1/3 the diameter from the top (overbuck). Then make the finished cut by underbucking the lower 2/3 to meet the first cut.

When bucking on a slope always stand on the uphill side of the log. To maintain control when “cutting through”, release the cutting pressure near the end of the cut without relaxing your grip on the chainsaw handles. Don’t let the chain contact the ground. After completing the cut, wait for the saw chain to stop before you move the chainsaw. Always stop the motor before moving from tree to tree.

### Limbing a tree

See figures 12 - 13.

Limbing is removing the branches from a fallen tree. When limbing, leave larger lower limbs to support the log off the ground. Remove the small limbs in one cut. Branches under tension should be cut from the bottom up to avoid binding the chainsaw.

### Springpoles

See figure 14.

A springpole is any log, branch, rooted stump, or sapling which is bent under tension by other wood so that it springs back if the wood holding it is cut or removed.

On a fallen tree, a rooted stump has a high potential of springing back to the upright position during the bucking cut to separate the log from the stump. Watch out for springpoles—they are dangerous.

**⚠ WARNING! Springpoles are dangerous and could strike the operator, causing the operator to lose control of the chainsaw. This could result in severe or fatal injury to the operator. This should be done by trained users.**



## ADDITIONAL SAFETY WARNINGS

Some regions have regulations that restrict the use of the product. Check with your local authority for advice.

Never allow children or people unfamiliar with the instructions to use the product. Local regulations may restrict the age of the operator.

Ensure before each use that all controls and safety devices function correctly. Do not use the product if the "off" switch does not stop the motor.

Wear full eye and hearing protection, strong sturdy boots and gloves, as well as head protection while operating the product. Use a face mask if operation is dusty.

Use of hearing protection reduces the ability to hear warnings (shouts or alarms). The operator must pay extra attention to what is going on in the work area.

Keep firm footing and balance. Do not overreach. Overreaching can result in loss of balance and can increase the risk of kickback.

Do not wear loose fitting clothing, short trousers, or jewellery of any kind.

Secure long hair so it is above shoulder level to prevent entanglement in moving parts.

Beware of thrown, flying, or falling objects. Keep all bystanders, children, and animals at least 15 m away from the work area.

Do not operate in poor lighting. The operator requires a clear view of the work area to identify potential hazards.

Operating similar tools nearby increases both the risk of hearing injury and the potential for other persons to enter your work area.

Keep all parts of your body away from any moving part.

Inspect the product before each use. Check for correct operation of all controls, including the chain brake. Check for loose fasteners, make sure all guards and handles are properly and securely attached. Replace any damaged parts before use.

Do not modify the product in any way or use parts and accessories which are not recommended by the manufacturer.

**⚠ WARNING! If the product is dropped, suffers heavy impact or begins to vibrate abnormally, immediately stop the product and inspect for damage or identify the cause of the vibration. Any damage should be properly repaired or replaced by an authorised service centre.**

Do not dispose of used battery packs in the household refuse or by burning them. AEG Distributors offer to retrieve old batteries to protect our environment.

Do not store the battery pack together with metal objects (short circuit risk).

Use only AEG BL1218 charger for charging battery packs. Do not use battery packs from other systems.

Compatible battery packs:

L1815R, L1820R, L1825R, L1830R, L1840R, L1850R, L1860R

Battery acid may leak from damaged batteries under extreme load or extreme temperatures. In case of contact with battery acid wash it off immediately with soap and water. In case of eye contact rinse thoroughly for at least 10 minutes and immediately seek medical attention.

## RESIDUAL RISKS

Even when the product is used as prescribed, it is still impossible to completely eliminate certain residual risk factors. The following hazards may arise in use and the operator should pay special attention to avoid the following:

- Injury caused by vibration
  - Always use the right tool for the job, use designated handles and restrict working time and exposure.
- Damage to hearing due to exposure to noise

- Wear hearing protection and limit exposure.
- Injury caused by contact with exposed saw teeth of the chain
- Injury caused by thrown-out pieces of the workpiece (wood chips, splinters)
- Injury caused by dust and particles
- Injury to the skin caused by contact with lubricants
- Parts ejected from the saw chain (cutting/injection hazards)
- Unforeseen, abrupt movement, or kickback of the guide bar (cutting hazards)

## RISK REDUCTION

It has been reported that vibrations from hand-held tools may contribute to a condition called Raynaud's Syndrome in certain individuals. Symptoms may include tingling, numbness and blanching of the fingers, usually apparent upon exposure to cold. Hereditary factors, exposure to cold and dampness, diet, smoking and work practices are all thought to contribute to the development of these symptoms. There are measures that can be taken by the operator to possibly reduce the effects of vibration:

- Keep your body warm in cold weather. When operating the unit wear gloves to keep the hands and wrists warm. It is reported that cold weather is a major factor contributing to Raynaud's Syndrome.
- After each period of operation, exercise to increase blood circulation.
- Take frequent work breaks. Limit the amount of exposure per day.
- Protective gloves available from professional chainsaw retailers are designed specifically for chainsaw use which give protection, good grip and also reduce the effect of handle vibration. These gloves should comply with EN381-7 and must be CE marked.

If you experience any of the symptoms of this condition, immediately discontinue use and see your physician.

**⚠ WARNING! Injuries may be caused, or aggravated, by prolonged use of a tool. When using any tool for prolonged periods, ensure you take regular breaks.**

## SPECIFIED CONDITIONS OF USE

The cordless chainsaw is only intended for use outdoors. For safety reasons the product must be adequately controlled by using two-handed operation at all times.

The product is designed for cutting branches, trunks, logs and beams of a diameter determined by the cutting length of the guide bar. It is only designed to cut wood. It is only to be used by adults who have received adequate training on the hazards and preventative measures/actions to be taken while using it.

Do not use the product for any purpose not listed in the Specified Conditions Of Use. It is not to be used for professional tree services. The product is not to be used by children or by persons not wearing adequate personal protective equipment and clothing.

**⚠ WARNING! When using the product, the safety rules must be followed. For your own safety and that of bystanders, you must read and fully understand these instructions before operating the product. You should attend a professionally organized safety course in the use, preventative actions, first-aid, and maintenance of chainsaws. Please keep these instructions safe for later use.**

**⚠ WARNING! Chainsaws are potentially dangerous tools. Accidents involving the use of chainsaws often result in loss of limbs or death. It is not just the chainsaw that is the hazard. Falling branches, topping trees, and rolling logs can all kill. Diseased or rotting timber poses additional hazards. You should assess your capability of completing the task safely.**



If there is any doubt, leave it to a professional tree surgeon.  
Do not use the product in any other way as stated for normal use.

## KNOW YOUR PRODUCT

See page 6-7.

1. Rear handle
2. Switch trigger
3. Trigger release
4. Front handle
5. Front hand guard/Chain brake
6. Chain cover
7. Bar mounting nuts
8. Chain tensioning screw
9. Chain catcher
10. Bar groove
11. Chain drive links
12. Saw chain
13. Guide bar cover
14. Guide bar
15. Spiked bumper
16. Chain lubricant cap
17. Combination wrench
18. Battery

## SAFETY DEVICES

### Low kick-back saw chain

A low-kick-back saw chain helps to reduce the possibility of a kickback event.

The rakers (depth gauges) ahead of each cutter can minimize the force of a kick-back reaction by preventing the cutters from digging in too deeply. Only use replacement guide bar and chain combinations recommended by the manufacturer.

As saw chains are sharpened, they lose some of the low kickback qualities and extra caution is required. For your safety, replace saw chains when cutting performance decreases.

### Spiked bumper

The integral bumper spike may be used as a pivot when making a cut. It helps to keep the body of the chainsaw steady while cutting. When cutting, push the machine forward until the spikes dig into the edge of the wood, then by moving the rear handle up or down in the direction of the cutting line it can help ease the physical strain of cutting.

### Guide bars

Generally, guide bars with small radius tips have somewhat lower potential for kick-back. You should use a guide bar and matching chain which is just long enough for the job. Longer bars increase the risk of loss of control during sawing. Regularly check the chain tension. When cutting smaller branches (less than the full length of the guide bar) the chain is more likely to be thrown off if the tension is not correct.

### Chain brake

Chain brakes are designed to quickly stop the chain from rotating. When the chain brake lever/hand guard is pushed towards the bar, the chain should stop immediately. A chain brake does not prevent kickback. It only lowers the risk of injury should the chain bar contact the operator's body during a kickback event. The chain brake should be tested before each use for correct operation in both the run and brake positions.

### Chain catcher

A chain catcher prevents the saw chain from being thrown back towards the operator if the saw chain comes loose or breaks.

## ASSEMBLY

**⚠ WARNING! If any parts are damaged or missing do not operate the product until the parts are replaced. Failure to heed this warning could result in serious personal injury.**

### Assembling saw chain and guide bar

See pages 10 - 11.

Make sure to remove the battery pack from the product. Wear protective gloves.

Remove the bar mounting nuts using the combination wrench provided.

Remove the chain cover.

The saw chain should face in the direction of chain rotation. If they face backwards, turn the loop over.

Place the chain drive links into the bar groove.

Position the chain so there is a loop at the back of the bar.

Attach the bar to the chain saw and loop the chain around the drive sprocket.

Replace the chain cover and bar mounting nuts.

Finger-tighten the bar mounting nuts. The bar must be free to move for chain tension adjustment.

Adjust the chain tension. Refer to the "Adjusting the chain tension" section.

Hold the tip of the guide bar up and tighten the bar mounting nuts securely.

### Adjusting the chain tension

See page 12.

Make sure to remove the battery pack from the product.

Make sure the bar mounting nuts are loosened to finger-tight.

To increase the chain tension, turn the chain tensioning screw clockwise and check the chain tension frequently. To reduce the chain tension, turn the chain tensioning screw counterclockwise and check the chain tension frequently.

The chain tension is correct when the gap between the cutter in the chain and the bar is about 4 - 5.5 mm. Pull the chain in the middle of the lower side of the bar downwards (away from the bar) and measure the distance between the bar and the chain cutters.

Tighten the bar mounting nuts by turning it clockwise.

**NOTE:** The temperature of the chain increases during normal operation causing the chain to stretch. Check the chain tension frequently and adjust as required. A chain tensioned while warm may be too tight upon cooling. Make sure that the chain tension is correctly adjusted as specified in these instructions.

## OPERATION

### Adding the chain lubricating oil

See page 13.

**⚠ WARNING! Never work without chain lubricant. If the saw chain is running without lubricant, the guide bar and the saw chain can be damaged. It is essential to frequently check the oil level in the oil level gauge and before starting to use the chainsaw.**

Clear surface around the oil cap to prevent contamination.

Unscrew and remove the cap from the oil tank.

Pour the oil into the oil tank and monitor the oil level gauge. Ensure that no dirt enters the oil tank while filling.

Put the oil cap back on and tighten it up. Wipe away any spillage.

One full oil tank will enable you to use the saw for 20- 60 min.



## Installing the battery pack

See pages 8 - 9.

Place the battery pack in the product. Align raised ribs on the battery pack with grooves in the product's battery port.

Make sure the latches on the battery pack snap in place and that the battery pack is secured in the chainsaw before beginning operation.

## Holding the chainsaw

See figure 1.

Always hold the product with your right hand on the rear handle and your left hand on the front handle. Grip both handles with the thumbs and fingers encircling the handles. Ensure that your left hand is holding the front handle so that your thumb is underneath.

## Starting the product

See page 14.

Before starting the product, you should install the battery pack in the product and make sure the chain brake is in run position by pulling the chain brake lever/hand guard toward the front handle.

To start the product: pull the trigger release, and then press the switch trigger.

## Checking and operating the chain brake

See page 15.

Engage the chain brake by rotating your left hand around the front handle. Allow the back of your hand to push the chain brake lever/hand guard toward the bar while the chain is rotating rapidly. Be sure to maintain both hands on the saw handles at all times.

Reset the chain brake back into the run position by grasping the top of the chain brake lever/hand guard and pulling toward the front handle until you hear a click.

**⚠ WARNING! If the chain brake does not stop the chain immediately, or if the chain brake will not stay in the run position without assistance, bring the product to an authorised service centre for repair prior to use.**

## TRANSPORTATION AND STORAGE

Stop the product, remove the battery pack, and allow the product to cool down before storing or transporting.

Clean all foreign material from the product. Store it in a cool dry and well-ventilated place that is inaccessible to children. Keep away from corrosive agents, such as garden chemicals and de-icing salts. Do not store outdoors.

Fit the guide bar cover before storing the product or during transportation.

For transportation, secure the product against movement or falling to prevent injury to persons or damage to the product.

## MAINTENANCE

**⚠ WARNING! Use only AEG accessories and AEG spare parts. Failure to do so can cause possible injury, contribute to poor performance, and may void your warranty. Should components need to be replaced which have not been described, please contact one of our AEG service agents (see our list of guarantee/service addresses).**

**⚠ WARNING! Servicing requires extreme care and knowledge and should be performed only by a qualified service technician. For service, bring the product to an authorised service centre for repair. When servicing, use only original replacement parts.**

**⚠ WARNING! Remove the battery before adjustment, maintenance or cleaning. Failure to do so could result in serious personal injury.**

You may only make adjustments or repairs described in this manual. For other repairs, contact the authorised service agent.

Consequences of improper maintenance may cause the chain brake and other safety features to not function correctly, thus increasing the potential for serious injury. Keep your chainsaw professionally maintained and safe.

Sharpening the chain safely is a skilled task. Therefore, the manufacturer strongly recommends that a worn or dull chain is replaced with a new one, available at your authorised service centre. The part number is available in the product specification table in this manual.

Follow instructions for lubricating and chain tension checking and adjustment.

After each use, clean the product with a soft dry cloth.

Check all nuts, bolts, and screws at frequent intervals for security to ensure the product is in safe working condition. Any part that is damaged should be properly repaired or replaced by an authorised service centre.

## Replacing the guide bar and saw chain

See pages 16 - 18.

Make sure to remove the battery pack from the product. Wear protective gloves.

Remove the bar mounting nuts using the combination wrench provided.

Remove the chain cover.

Remove the bar and saw chain from the product.

Put the new chain in the correct direction onto the bar and make sure that the drive links are aligned in the bar groove.

Attach the bar to the chain saw and loop the chain around the drive sprocket.

Replace the chain cover and bar mounting nuts.

Finger-tighten the bar mounting nuts. The bar must be free to move for chain tension adjustment.

Adjust the chain tension. Refer to the "Adjusting chain tension" section.

Hold the tip of the guide bar up and tighten the bar mounting nuts securely.

**⚠ WARNING! A dull or improperly sharpened chain can cause excessive motor speed during cutting which may result in severe motor damage.**

**⚠ WARNING! Improper chain sharpening increases the potential of kickback.**

**⚠ WARNING! Failure to replace or repair a damaged chain can cause serious injury.**

**⚠ WARNING! The saw chain is sharp. Always wear protective gloves when performing maintenance to the chain.**

## Inspecting and cleaning the chain brake

Always keep the chain brake mechanism clean by lightly brushing the linkage free from dirt.

Always test the chain brake performance after cleaning. Refer to "Checking and operating the chain brake" section in this manual for additional information.



## MAINTENANCE SCHEDULE

Daily check	
Bar lubrication	Before each use
Chain tension	Before each use and frequently
Chain sharpness	Before each use, visual check
For damaged parts	Before each use
For loose fasteners	Before each use
Chain brake function	Before each use
Inspect and clean	
Bar	Before each use
Complete saw	After each use
Chain brake	Every 5 hours of operation

Spare parts	Oregon
Chain	90PX045X
Bar	124MLEA041

### Exploded view

If needed, an exploded view of the tool can be ordered. Please state the machine type printed as well as the six-digit No. on the label and order the drawing at your local service agents or directly at: Techtronic Industries GmbH, Max-Eyth-Straße 10, 71364 Winnenden, Germany.

## BATTERIES

Battery packs which have not been used for some time should be recharged before use.

Temperatures in excess of 50°C (122°F) reduce the performance of the battery pack. Avoid extended exposure to heat or sunshine (risk of overheating).

The contacts of chargers and battery packs must be kept clean.

For an optimum life-time, the battery packs have to be fully charged, after used.

To obtain the longest possible battery life remove the battery pack from the charger once it is fully charged.

For battery pack storage longer than 30 days:

Store the battery pack where the temperature is below 27°C and away from moisture.

Store the battery packs in a 30% - 50% charged condition.

Every six months of storage, charge the pack as normal.

## TRANSPORTING LITHIUM BATTERIES

Lithium-ion batteries are subject to the Dangerous Goods Legislation requirements.

Transportation of those batteries has to be done in accordance with local, national and international provisions and regulations.

- The user can transport the batteries by road without further requirements.
- Commercial transport of Lithium-Ion batteries by third parties is subject to Dangerous Goods regulations. Transport preparation and transport are exclusively to be carried out by appropriately trained persons and the process has to be accompanied by corresponding experts.

When transporting batteries:

- Ensure that battery contact terminals are protected and insulated to prevent short circuit.
- Ensure that battery pack is secured against movement within packaging.
- Do not transport batteries that are cracked or leak.

Check with forwarding company for further advice

## SYMBOLS



Safety alert



Read and understand all instructions before operating the product, follow all warnings and safety instructions.



Wear eye, ear and head protection.



Wear non-slip safety footwear when using the product.



Wear non-slip, heavy duty gloves.



Wear eye and face protection.



Wear upper body protection.



Wear leg protection.



Beware of chain saw kickback and avoid contact with bar tip.



Do not expose to rain or damp condition.



Moving direction of the chain. (Marked under the chain cover)



Hold and operate the saw properly with both hands.



Do not operate the saw using only one hand.



Remove the battery pack before starting any work on the product.



Do not burn used battery packs.



Never charge a damaged battery pack. Replace with a new one.





Set the chain brake to the RUN position.



Rotate to adjust chain tension  
+ = Tighten the chain  
- = Loosen the chain



Set the chain brake to the BRAKE position.

$V_G$ : 10 m/s No-load chain speed is 10 m/s

L max: 300 mm Maximum guide bar length is 300 mm



The guaranteed sound power level is 99 dB.



Conforms to all regulatory standards in the country in the EU where the product is purchased.



EurAsian Conformity Mark



Ukrainian mark of conformity



Do not dispose of electric tools together with household waste material! In observance of European Directive 2002/96/EC on waste electrical and electronic equipment and its implementation in accordance with national law, electric tools that have reached the end of their life must be collected separately and returned to an environmentally compatible recycling facility.



Li-Ion

Do not dispose of used battery packs in the household refuse or by burning them. Hand them over to applicable collection points.

The following signal words and meanings are intended to explain the levels of risk associated with this product.

**⚠ DANGER**

Indicates an imminently hazardous situation, which, if not avoided, will result in death or serious injury.

**⚠ WARNING**

Indicates a potentially hazardous situation, which, if not avoided, could result in death or serious injury.

**⚠ CAUTION**

Indicates a potentially hazardous situation, which, if not avoided, may result in minor or moderate injury.

**CAUTION**

Without safety alert symbol

Indicates a situation that may result in property damage.

**EC-DECLARATION OF CONFORMITY**

We declare under our sole responsibility that the product described under "Technical Data" fulfills all the relevant provisions of the directives 2011/65/EU (RoHS), 2014/30/EU, 2006/42/EC, 2000/14/EC, 2005/88/EC, and the following standards have been used:

- EN 60745-1:2009+A11:2010
- EN 60745-2-13:2009+A1:2010
- EN ISO 3744:2010
- EN 55014-1:2006+A1:2009+A2:2011
- EN 55014-2:2015
- EN 50581:2012

Measured sound power level 94.2 dB(A)  
Guaranteed sound power level 99 dB(A)

Conformity assessment method to Annex V Directive 2000/14/EC amended by 2005/88/EC

Notified body, 0197 TÜV Rheinland LGA Products GmbH; Tillystraße 2 D - 90431 Nürnberg, Germany has carried out EC type approval, and the certificate number is : BM 50367224 0001

Winnenden, 08 March 2017

Alexander Krug  
Managing Director



Authorised to compile the technical file.

Techtronic Industries GmbH  
Max-Eyth-Straße 10,  
71364 Winnenden,  
Germany





1  
t  
/  
3

/

;  
t  
4







# AEG

## POWERTOOLS

[www.aeg-powertools.eu](http://www.aeg-powertools.eu)

Techtronic Industries GmbH  
Max-Eyth-Straße 10  
71364 Winnenden  
Germany

960994077-02